

Type: 1610-21



Miniaturised single pole press-to-reset cycling trip free thermal circuit breaker designed for automotive fuse block installation. Extends the benefits of circuit breaker performance and convenience to applications which are cost critical. Colour-coded housing caps available.

Version 1616 is available especially for the automotive industry (current ratings correspond to those of blade fuses).

Voltage rating:

- DC 32 V

Current ratings:

from 5 A to 30A

Number of poles:

single pole

Mounting method:

socket

Terminal design:

blade terminals

Actuation:

push button

Auxiliary contacts:

without auxiliary contacts

Water splash protection:

without water splash protection

Illumination:

without illumination

Typical life:

300 operations at ≤ 50 A

Interrupting capacity I_{cn} :

- ≥ 3 break operations at 150 A, or
- ≥ 1 break operation at 2,000 A

Dimensions

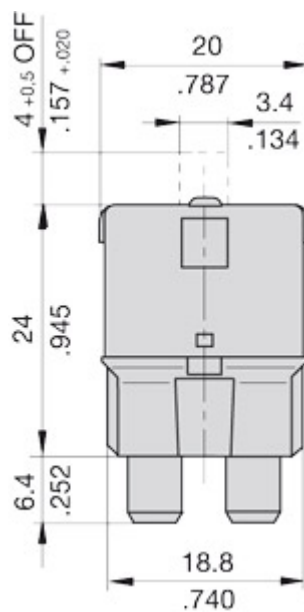

Internal connection diagrams

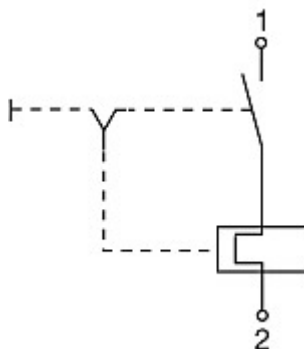

Description

Miniaturised single pole press-to-reset cycling trip free thermal circuit breaker designed for automotive fuse block installation. Extends the benefits of circuit breaker performance and convenience to applications which are cost critical. Colour-coded housing caps or manual release buttons available.

Typical applications

Extra low voltage wiring systems on all types of vehicles and marine craft.

Ordering information

Type No.						
1610	single pole automotive circuit breaker					
Voltage rating						
21	DC 28 V					
H2	DC 28 V, with manual release facility (type III to SAE J 553)					
92	DC 12 V, autoreset (type I to SAE J 553)					
Current ratings						
6	8	10	15	20	25	30 A
1610 - 21 - 8 A ordering example						

Current ratings, typical voltage drop values and colour coding

Current rating (A)	Voltage drop (mV)	Actuator colour manual release (1610-H2) or housing cap colour (1610-21)
6	< 150	mossy-green (approximating RAL 6005)
8	< 150	honey (approximating RAL 1005)
10	< 150	red (approximating RAL 3020)
15	< 150	blue (approximating RAL 5012)
20	< 150	yellow (approximating RAL 1018)
25	< 150	pearl (approximating RAL 1013)
30	< 150	light-green (approximating RAL 6018)

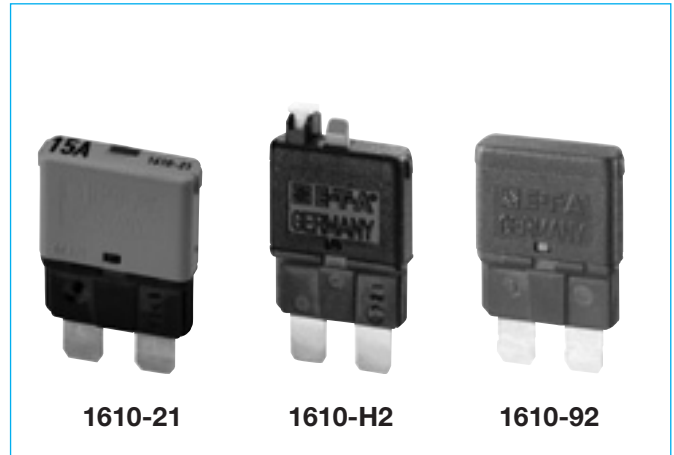

Technical data

Voltage rating	1610-92: DC 12 V 1610-21/1610-H2: DC 32 V
Current ratings	6...25 A (30 A upon request)
Service short-circuit breaking capacity	300 operations at ≤ 50 A
Reset period for 1610-92 (at 23 °C)	≤ 15 s
Ambient temperature	-30...+60 °C (-22...+140 °F)
Degree of protection (IEC 60529/DIN 40050)	operating area IP30 (-21/-H2) operating area IP54 (-92) terminal area IP00
Ultimate short-circuit breaking capacity	≥ 3 break operations at 150 A, or ≥ 1 break operation at 2,000 A
Vibration (with mounting socket 12)	5 g (57-500 Hz) ± 0.38 mm (10-57 Hz) to IEC 60068-2-6, test Fc 10 frequency cycles/axis
Shock (with mounting socket 12)	25 g (11 ms) to IEC 60068-2-27, test Ea
Corrosion	96 hours at 5 % salt mist, to IEC 60068-2-11, test Ka
Humidity	240 hours at 95 % RH, to IEC 60068-2-3, test Ca
Mass	approx. 5 g

N.B.

It is good practice to switch off the vehicle's ignition system before re-setting the circuit breaker. Free travel of the actuator must be ensured.

Dimensions

1610-21

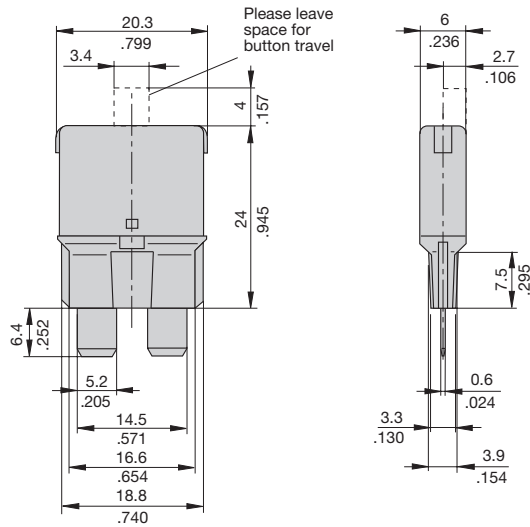

1610-H2

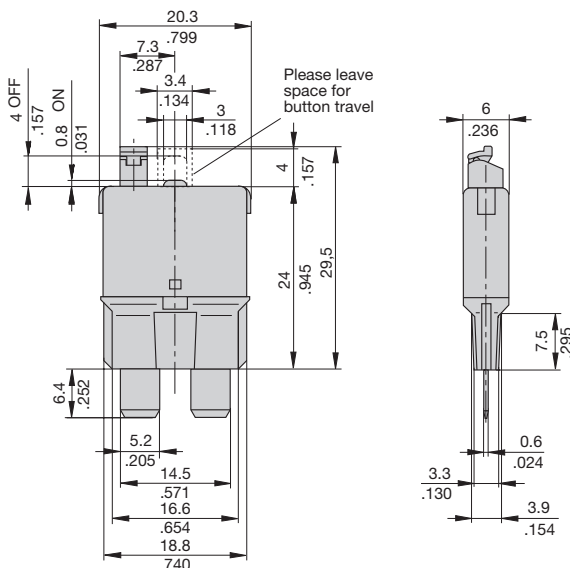

1610-92

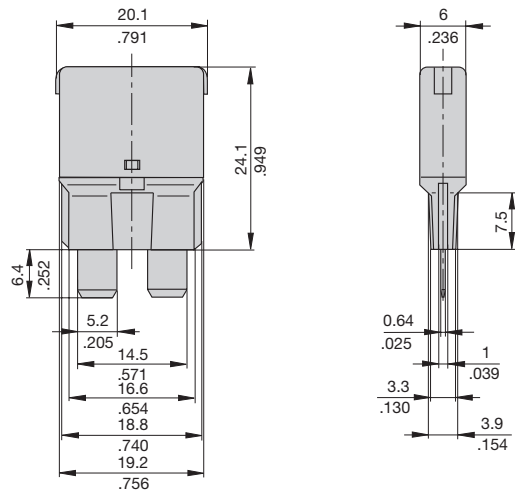

Internal connection diagrams

1610-21

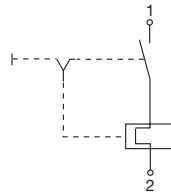

1610-H2

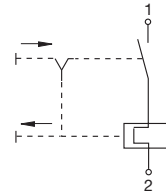

1610-92

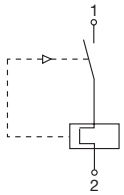

Typical time/current characteristic curve

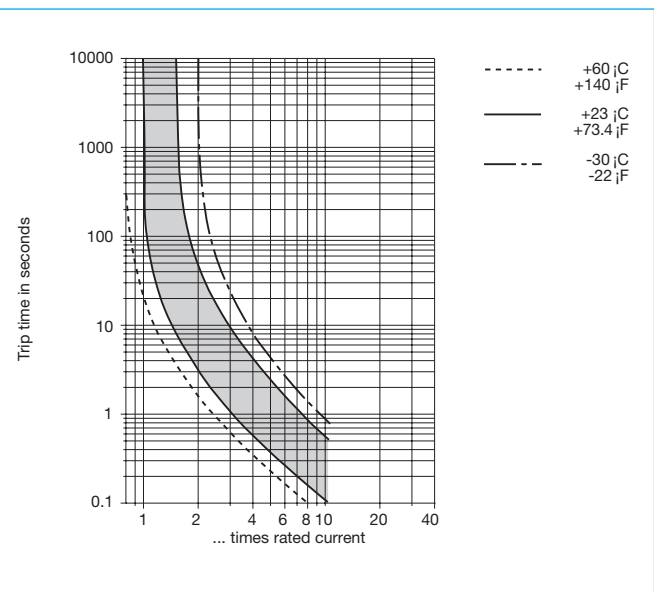

Accessories

Cover Y 307 207 01

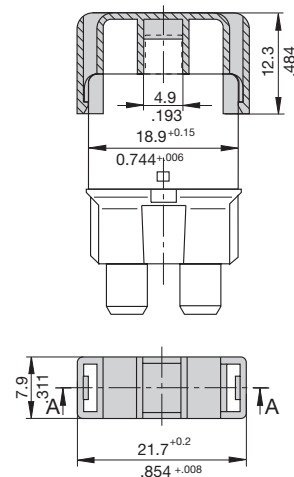

This is a metric design and millimeter dimensions take precedence ($\frac{\text{mm}}{\text{inch}}$)